

Direct & Indirect  
Unvented Cylinder  
Installation & Maintenance  
Manual



Please register your product online at [www.jouleuk.co.uk](http://www.jouleuk.co.uk)  
Please leave this product guide with the user following installation.

Homeowner \_\_\_\_\_

Address \_\_\_\_\_  
\_\_\_\_\_  
\_\_\_\_\_

Contact Tel. \_\_\_\_\_

Contact Email \_\_\_\_\_

Product	Product Installed (Check)	Serial Number		Installation Date
Cylinder			Located in Cylinder badge	
Solar Thermal			Taken From Solar Controller	
Solar PV			One Ser. No. from String / Micro Inverter	
Air Source Heat Pump			Located on External Heat Pump Badge	
Integrated Heat Pump and Cylinder			Located on Cylinder Badge	
Underfloor Heating			Project Ref. on Supplied Schematic	
Direct Gas Fire Cylinder			Located on Cylinder Badge	

Installer \_\_\_\_\_

Address \_\_\_\_\_  
\_\_\_\_\_  
\_\_\_\_\_

Contact Tel. \_\_\_\_\_

Contact Email \_\_\_\_\_

Joule Advance Installer

I accept the terms and conditions available to view on jouleuk's website

---

# Table of Contents

4	Introduction
9	General Requirements
16	Direct Technical Specification
20	Direct Installation Mechanical Diagram
21	Testing
24	Indirect Technical Specification
28	2 Port Mechanical Diagram
29	2 Port Electrical Diagram
30	3 Port Mechanical Diagram
31	3 Port Electrical Diagram
32	Electronic Controls
33	Discharge Arrangement
36	Commissioning
37	Maintenance
39	Taking The Cylinder Out Of Use
41	Troubleshooting
43	Guarantee
44	Notes
48	Benchmark Service Record
50	System Record

The instructions are an integral part of the appliance and must be given to the end user on completion of the installation in order to comply with the current regulation.

It is important to carefully read the manual to understand all the information to enable safe installation, use and servicing. These instructions consist of details for installation, servicing, fault finding and replacement of parts for the cylinder purchased.

JOULE will not accept any liability in the event of damage for not complying with the guidance in this instruction manual.

The instructions for this installation manual apply to the range of JOULE Cyclone Indirect Unvented Cylinders.

Safety is paramount when installing unvented hot water systems and the following instructions must be adhered to:

Only certified competent installers can install, commission and service the equipment supplied.

The cylinder must be used for potable hot water only. Any other applications will be considered incorrect use and JOULE will not be held liable for any losses resulting from such use.

All installation and maintenance instructions must be observed to ensure the correct operation of the equipment.

The electric immersion must not be switched on unless the cylinder is completely full of water.

Domestic hot water may be stored at temperatures exceeding 60°C. Preventative measures should be put in place to negate the possibility of scalding.

A maintenance schedule should be put in place with a competent person to service the equipment annually to comply with the warranty conditions.

When servicing the system the mains supply to the cylinder should be isolated.

Only genuine spare parts should be used. A full list of items with relevant codes can be found on page 13 .

The installation must be carried out by a person competent to install unvented hot water systems. The installation must be carried out in accordance with the following recommendations:

All current Building Regulations issued by the Department of the Environment, i.e. Approved Document L1 Building Standards (Scotland) (Consolidation) Regulations issued by the Scottish Development Department UK Water Regulations/Byelaws (Scotland) Health & Safety Document No. 635 (The Electricity At Work Regulations 1989) The installations should also be in accordance with the following British Standard Codes of Practice:

BS 5449:1990 Forced circulation hot water systems

BS 5546:2000 Installation of hot water supplies for domestic purposes

BS 5918:1989 Solar heating systems for domestic hot water

BS 6700:2006 Design, installation, testing and maintenance of services supplying water.

Failure to install this appliance correctly could lead to prosecution and will invalidate the guarantee. It is in your own interest and that of safety to ensure that the law is complied with.

## HANDLING

Care must be taken when transporting, storing and installing the equipment:

At least two people should lift the cylinder to prevent injuries.

The cylinder must be stored in a dry area and must never be set down hard during handling.

Packaging should only be removed at the installation location.

The cylinder must be installed on a level floor with the required load bearing capability.

Installation, servicing, maintenance and repair must be carried out by a competent person.

All electrical wiring must be carried out by a qualified electrician and be installed in accordance with current I.E.E Wiring Regulations.

A lack of safety devices can lead to potentially fatal injuries, all necessary safety devices must be installed correctly in the system. The use of an electric immersion may lead to the build up of electrical potential in the water. This can in turn cause corrosion of the immersion. To prevent this, ensure the immersion heater, and the hot and cold pipework are correctly bonded and connected to the earth line.

If plastic pipes are used they must be approved temperature resistant to 95°C at a pressure of 10 Bar.

A thermostatic mixer should be installed in the system to prevent the risk of scalding. If there are leaks found in the system, shut off the cold water stop valve from the main supply and contact a competent person immediately.

### WHAT IS BENCHMARK?

Benchmark places responsibilities on both manufacturers and installers. The purpose is to ensure that customers are provided with the correct equipment for their needs, that it is installed, commissioned and serviced in accordance with the manufacturer's instructions by competent persons and that it meets the requirements of the appropriate Building Regulations.

The Benchmark Checklist can be used to demonstrate compliance with Building Regulations and should be provided to the customer for future reference. Installers are required to carry out installation, commissioning and servicing work in accordance with the Benchmark Code of Practice which is available from the Heating and Hotwater Industry Council who manage and promote the scheme. Visit [www.centralheating.co.uk](http://www.centralheating.co.uk)

### WATER SUPPLY

The performance of any unvented system is only as good as the mains water supply available. To this effect the maximum possible water demand should be assessed, with the knowledge that the mains supplies both hot and cold services simultaneously.

The water heater itself operates at a pressure of 3 bar, controlled by the inlet control set, and is capable of delivering over 50 litres per minute. The high quality inlet control set has been designed to make the most of the flow rates available.

The water supply should be checked to ensure it can meet these requirements. If necessary, consult the local water authority regarding the likely pressure and flow rate availability.

Consideration should be given to upgrading existing ½" (15mm) cold mains pipe-work to a larger size if the recommended minimum pressure/flow rate is not being achieved. JOULE recommend that primary pipework used has a minimum diameter of 22mm to ensure low pressure loss.

Note: A high static (no flow) mains pressure is no guarantee of good flow availability. In a domestic installation 1.5 bar and 25 l/min. should be regarded as the minimum. The maximum mains pressure that the inlet control set can cope with is 10 bar.

## CHANGE OF WATER SUPPLY

The changing or alternating from one water supply to another can have a detrimental effect on the operation and / or life expectation of the water heater storage cylinder, pressure temperature relief valve and heating unit.

Where there is a changeover from one water supply to another, e.g. a rainwater tank supply, bore water supply, desalinated water supply, public reticulated water supply or water brought in from another supply, then water chemistry information should be sought from the supplier or it should be tested to ensure the water supply meets the requirements given in these guidelines for the Joule warranty to apply.

## WATER CHEMISTRY

This water heater must be installed in accordance with this advice to be covered by the Joule warranty. This water heater is manufactured to suit the water conditions of most public reticulated water supplies. However, there are some known water chemistries which can have detrimental effects on the water heater and its operation and / or life expectancy. If you are unsure of your water chemistry, you may be able to obtain information from your local water supply authority. We recommend not to use water softener, however if it is used the water is required to be kept at potable standards. This water heater should only be connected to a water supply which complies with these guidelines for the JOULE warranty to apply.

## WATER CHEMISTRY LEVELS AFFECTING WARRANTY

The JOULE warranty of this water heater will not cover resultant faults on components including the storage cylinder where water stored in the storage cylinder exceeds at any time any of the following levels:

Components	Maximum Permitted Levels
Total Dissolved Solids	600 mg/Litre
Total Hardness	200 mg/Litre
Chloride	300 mg/Litre
Magnesium	10 mg/Litre
Calcium	20 mg/Litre
Sodium	150 mg/Litre
Iron	1 mg/Litre
Maximum pH	9.5
Minimum pH	6.5

## TOTAL DISSOLVED SOLIDS (TDS)

Some water analysis reports may state the conductivity of the water rather than the level of total dissolved solids. Conductivity, measured in microsiemens per centimetre ( $\mu\text{S} / \text{cm}$ ), is directly proportional to the TDS content of the water. TDS, in  $\text{mg} / \text{L}$ , is approximately 70% of the conductivity in  $\mu\text{S} / \text{cm}$ .

The JOULE warranty will not cover resultant faults to the storage cylinder if this water heater is connected at anytime to a water supply where the TDS content of the water exceeds  $600 \text{mg} / \text{L}$ . In locations where TDS approaches  $600 \text{mg} / \text{L}$ , e.g. due to sediment, we strongly recommend fitting an appropriate filter to ensure water entering or in the water heater does not exceed this level at any time i.e. due to sediment build up.

## FEATURES OF THE UNVENTED CYLINDER

- Made from Duplex Stainless Steel for excellent corrosion resistance.
- Strong rust-proofed steel case.
- Insulation is by means of an approved CFC/HCFC free polyurethane foam with an ozone depletion factor of zero.
- Available in a variety of sizes to suit - 100L, 125L, 150L, 170L, 200L, 250L, 300, 400 and 500 litres.
- All models including Solar models are available in Twin or Triple versions  
Supplied complete with all the necessary safety and control devices needed to connect to cold water mains
- All safety and control devices are pre-set.
- High quality controls selected that combine high flow rate performance with minimum pressure drop which gives fantastic performance in all areas, with great improvements in areas with poor water pressure.

## WELLMASTER CYLINDERS

Only JOULE Wellmaster cylinders may be installed on a well, private water scheme or any water source that does not come from the public mains.

Water supplied to the cylinder must conform to the water chemistry table on the previous page. A descaler on the cold water feed may be used if required.

If any of the water parameters are higher than set out in the table including Total Hardness regardless of whether or not it is fed from a main water connection a JOULE Wellmaster cylinder must be used.

## SITING THE UNIT

This unit can supply outlets above it or at some distance from it but any outlets above the unit will reduce the available outlet pressure by 0.1 bar for every 1m of height difference. The maximum length of the “dead leg” should be as stated in the Water Supply (Water Fittings) Regulations 1999 G18.7, in particular to the area of most frequent use.

Particular attention is needed if sitting in a garage or outbuilding as the unit should be protected from frost. All exposed pipework must be insulated. The unit must be installed UPRIGHT on a flat base capable of supporting its weight when full (please see the technical specification section for weights).

Sufficient access to allow maintenance of the valves should be considered. In addition the immersion heaters are 400mm in length and this distance should be considered to allow withdrawal for servicing if required. The discharge pipework from the safety valves should fall continuously and terminate safely.

Negative pressure may form in cylinders installed very high in a building. To counteract this, an anti-vacuum valve can be installed to prevent damage to the cylinder. The anti-vacuum valve ensures that pressure compensation as a result of air flowing into the cylinder.

## CONNECTING TO THE CYLINDER

All of the pipework connections on the cylinder are female threaded. Upon filling / commissioning, ensure all connections are completely watertight.

Note: No control or isolation valve should be fitted between the expansion relief valve and the storage cylinder. The relief valve connections should not be used for any other purpose.

## COLD MAINS PIPEWORK

Run the cold main through the building to the place where it is to be installed. Take care not to run the cold pipe near hot water or heating pipe work so that the heat pick-up is minimized. Identify the cold water supply pipe and fit an isolating valve (not supplied). A 22mm BS1010 stopcock can typically be used but a 22mm quarter turn full bore valve would be better as it does not restrict the flow as much. Do not use “screw-driver slot” or similar valves.

Make the connection to the cold feed of the cylinder and incorporate a drain valve. Position the inlet control just ABOVE the Temperature & Pressure Relief Valve (TPRV) mounted on the side of the cylinder. This ensures that the cylinder does not have to be drained down in order to service the inlet control set. Ensure that the arrow points in the direction of the water flow. Select a suitable position for the expansion vessel. Mount it to the wall using the bracket provided. Use the flexible hose provided to connect to the inlet control group.

### BALANCED COLD CONNECTION

If there are to be showers, bidets or monobloc taps in the installation then a balanced cold supply is necessary. There is a 22mm balanced connection on the inlet control set.

### FITTING THE INLET CONTROL GROUP

Excess pressure can lead to the cylinder bursting. The inlet control set supplied has an expansion relief valve with a 15mm connection to allow it to be connected to the tundish. Make sure that there is sufficient space for future maintenance and also for connection of the discharge pipe for the expansion relief valve.

It is essential that this connection is not covered or closed. The hot water expansion vessel can be fitted to the inlet control group using the supplied expansion vessel flexible hose.

### HOT WATER PIPEWORK

Run the first part of the hot water distribution pipework in 22mm. This can be reduced to 15mm and 10mm as appropriate for the type of tap etc. Your aim should be to reduce the volume of the hot draw-off pipework to a practical minimum so that the time taken for the hot water is as quick as possible.

Do not use monobloc mixer tap or showers if the balanced cold connection is not provided. Outlets of this type can back pressurise the unit and result in discharge.

### EXPANSION VESSEL

The expansion vessel receives the increased water volume when expansion takes place as the system heats up and it maintains a positive pressure in the system. The expansion vessel contains a flexible diaphragm, which is initially charged on one side with nitrogen, but can be topped up with air when required.

Select a suitable position for the expansion vessel. Mount it to the wall using the bracket provided and connect to the inlet control set with the flexible hose provided. Ensure that the top of the vessel is accessible for servicing. The pipe connecting the expansion vessel to the system should have a diameter of not less than 15mm and must not contain any restrictions.

Prior to connecting the expansion vessel to the system the pipework should be flushed and tested. When the vessel is connected the system should be pressurised when cold. If the initial system water pressure is too high, the diaphragm will be displaced too far into the vessel. This will leave the vessel unable to accommodate the volume of expansion water. The result of this is an increase in system pressure and the safety valve will lift.

### PRIMARY COIL CONNECTIONS

Connect the primary connections (Indirect only). The primary circuit must be positively pumped. Either primary connection may be used as the primary flow. Reheat times are identical either way. The primary circuit can be open vented or sealed, with up to a maximum pressure of 3.5 bar. If you seal the primary circuit an additional expansion vessel and safety valve is required.

The boiler may be Gas, Electric or Oil but must be under effective thermostatic control. Uncontrolled heat sources such as some AGA's, back boilers, solid fuel stoves, etc. are NOT SUITABLE. Please contact our Technical department for guidance. Connect the two port zone valve (indirect only) into the primary flow pipework. The direction of flow arrow should be towards the primary flow connection.

### INSTALLING THE TWO PORT MOTORISED VALVE

The function of the Two Port Motorised Valve prevents the cylinder from overheating. It can be installed on either horizontal or vertical pipework.

If it is mounted onto horizontal pipework the valve head must face upwards. The direction of flow is marked on the body of the valve with arrows.

### THERMOSTATIC MIXER

When installing a solar system with an unvented JOULE Cyclone twin coil cylinder, a thermostatic mixing valve should be installed. Its function is to act as an anti scald protection. The thermostatic mixer is to be set to a temperature of between 30°C and 60°C and is supplied by the installer.

## UNVENTED KIT COMPONENTS

Direct	Indirect
Inlet Control Group	Inlet Control Group
Tundish	Tundish
T & P Valve (fitted)	T & P Valve (fitted)
3kW Immersion (fitted)	3kW Immersion (fitted)
Expansion Vessel	Expansion Vessel
Expansion Vessel Hose	Expansion Vessel Hose
	Dual Cylinder Stat
	2 Port Zone Valve



## SECONDARY CIRCULATION

On larger installations long pipe runs to draw-off points can cause significant volumes of water to be drawn off before an acceptable temperature can be reached. Secondary pumped circulation using a stainless steel or a bronze pump, and combined with effective time and temperature controls can overcome this problem. Where secondary return circulation is required the pipework should be run in 15mm pipe. A suitable WRAS approved stainless steel or bronze circulation pump must be used. A check valve must also be installed to prevent backflow.

On large secondary circulation systems it may be necessary to incorporate an extra expansion vessel into the circuit to accommodate the increased system water volume. Secondary circulation should be avoided on Direct electrically heated units being used on off-peak electricity tariffs. It should be noted that the use of a secondary circulation circuit can increase running costs as there will be circulation pipe losses. High levels of insulation on secondary pipework are required to keep energy losses to a minimum.

Capacity (L)	100	125	150	170	200	250	300	400	500	
Expansion Vessel	TV-P-000019L						TV-P-000024L	TV-P-000035L	TV-P-000050L	
Dual Stat	TZC-D-000000Z									
Primary Coil 2 Port Zone Valve	TZM-I-00022MM									
Inlet Group	TZG-3.0-0.75L							TZG-3.0-0001L		
T&P Relief Valve	TZ9-4.0-0000.5 (½" up to 300L)						TZ9-4.0-000.75 (¾")			
Immersion	TI-I-L-14-3-1									
Tundish	TZU-000015X22							TZU-0000022X1		

## DEAD LEGS

The length of hot water draw off to taps and other outlets should be kept to a minimum to reduce the amount of cold water drawn off before the hot water arrives. The maximum recommended dead leg lengths are shown in figure 2.b. Where there is more than one size of pipe on a dead leg, the equivalent length and size should be estimated.

Where the dead leg length exceeds the recommended maximum, secondary circulation should be installed. It should be controlled by a time switch and incorporate a motorized valve that can prevent gravity circulation in the circuit.

Pipe Size (mm)	Maximum Length (m)
10, 12	20
15, 22	12
28	8
35 and above	3

## SYSTEM NOISE

Noise in pipework may occur as a result of expansion of pipework over joists or where the pipe has been left touching other pipes or a part of the building structure. Care must be taken to ensure that the pipework is correctly bracketed, is not in tension or compression, and does not carry the weight of components such as a circulation pump.

## SETTING THE HOT WATER TEMPERATURE

The hot water temperature is set on the dual thermostat by the competent person during the installation. The dual thermostat should be set to 60°C. If you are heating water in the cylinder for the first time, or the time controls for the DHW zone have been off for a prolonged period of time, the cylinder may take additional time to heat up.

### WARNING

Inappropriate adjustments can lead to the damages in the system. If any changes are made to the cylinder, the controls, the water and power supply lines or the expansion relief components there is a risk of steam escaping or rupture to the system.



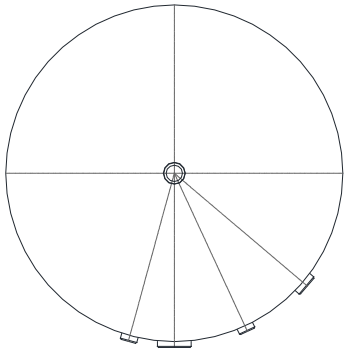
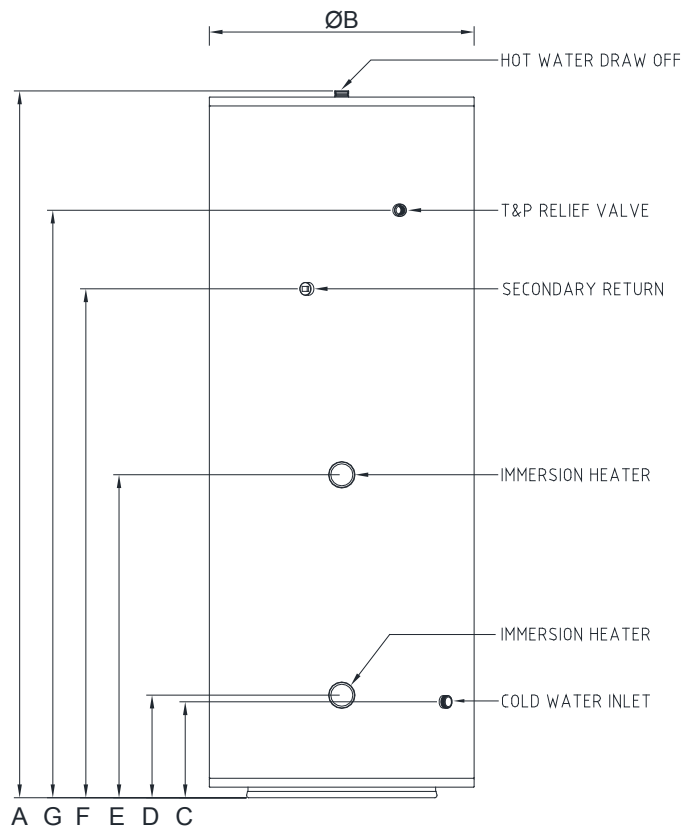

# Direct Technical Specification

Capacity	100L	125L	150L	170L	200L	200L	250L	250L	300L	300L	400L	500L
A (mm)	950	1030	1190	1310	1150	1490	1400	1815	1600	2040	1570	1900
B (mm)	500	530	530	530	600	530	600	530	600	530	710	710
C (mm)	188	196	196	196	218	196	218	196	218	196	225	225
D (mm)	203	211	211	211	233	211	233	211	233	211	240	240
E (mm)	468	511	561	631	553	701	653	861	733	1001	740	840
F (mm)	628	651	786	881	768	981	968	1271	1153	1551	1180	1440
G (mm)	743	751	911	1031	883	1211	1133	1531	1333	1811	1280	1640
Heat Up Time - From 15°C to 60°C (Mins)	52	62	76	96	119	119	140	140	166	166	225	260
Re-heatTime-70%DRAW OFF (mins)	32	40	50	66	83	83	98	98	121	121	165	190
Weight - Empty (kg)	36	30	34	37	40	41	49	49	56	55	62	89
Weight - Full (kg)	135	155	184	207	240	241	299	299	356	355	462	587
Cold Water Inlet	22mm										1" F (DN25)	
Hot Water Draw Off	22mm										1" F (DN25)	
Immersion Heater	1¾" F											
Secondary Return	½" F (BLANK)											
T&P Relief Valve	½" F (DN15)										¾" F (DN20)	
Operating Pressure	3 bar											
Maximum Design Pressure	7 bar											
Max Water Supply Pressure	10 bar											
Max Primary Working Pressure	3 bar											
Immersion Heater	3kW/240V - 1.75" - 14" Long											
Expansion Vessel Charge Pressure	2.7 bar											
Maximum Operating Temperature	90°C											
Pressure Reducing Valve Set To	3 bar											
Expansion Reducing Valve Set To	6 bar											
Pre-charge Pressure Of The Expansion Valve	3 bar											
Pressure/Temperature Relief Valve Set To	7 bar / 90°C											

Note: Heat and reheat times are a guide and are based on a primary flow temperature of 60°C and a temperature rise from 15°C to 60°C.

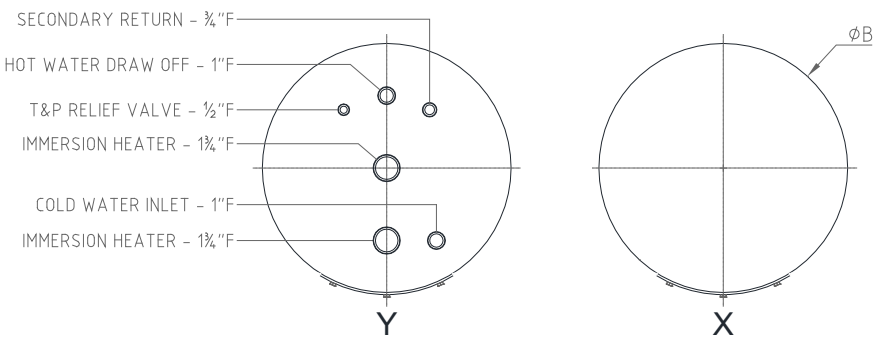
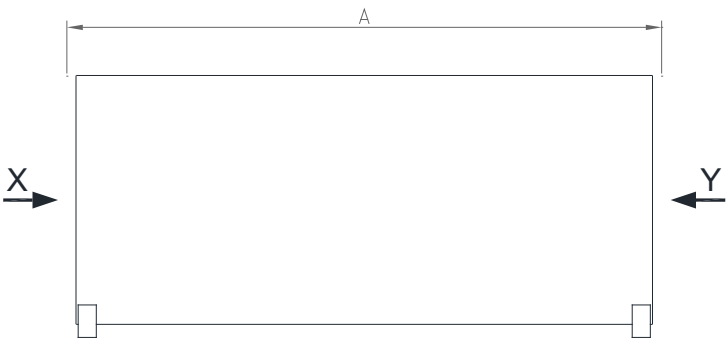

Capacity	150L	170L	200L	250L	300L
A (mm)	1085	1205	1085	1335	1535
B (mm)	530	530	600	600	600
Heat Up Time (Mins)	76	96	119	140	166
Weight - Empty (kg)	34	37	40	49	56
Weight - Full (kg)	184	207	240	299	356
Operating Pressure	3 Bar				
Max Water Supply Pressure	10 Bar				
Max Primary Working Pressure	3 Bar				

		100L	125L	150L	175L	200L	200L	250L	250L	300L	300L	400L	500L
Direct	Hot Water Storage Tank Volume (L)	99	127	150	169	200	200	250	251	294	292	395	498
	Load Profile	L	L	L	L	L	L	L	L	XL	XL	XXL	XXL
	Energy Efficiency Class	C	C	C	D	D	D	D	D	D	D	D	D
	Energy Efficiency (%)	37	37	37	36	36	35	35	35	37	36	37	36
	AnuualElectricityConsumption(kWh)	2740	2773	2785	2830	2875	2892	2908	2928	4565	4610	5805	5999
	Sound Power Level (dB)	16	16	16	16	16	16	16	16	16	16	16	16
	Thermostat Temperature Setting (°C)	60	60	60	60	60	60	60	60	60	60	60	60
	Standing Loss (w)	44	52	55	58	78	81	87	89	92	103	102	115
	Standing Heat Loss (kWh/24hr)	1.06	1.25	1.32	1.39	1.87	1.94	2.09	2.14	2.21	2.47	2.45	2.76

		150L (1140x530)	170L (1205x530)	200L (1085x600)	250L (1135x600)	300L (1535x600)
Direct Horizontal	Load Profile	L	L	L	L	XL
	Energy Efficiency Class	D	D	D	D	D
	Energy Efficiency (%)	36	35	35	35	36
	AnuualElectricityConsumption(kWh)	2818	2901	2933	2949	4614
	Sound Power Level (dB)	16	16	16	16	16
	Thermostat Temperature Setting (°C)	60	60	60	60	60

According to EN 12897:2006

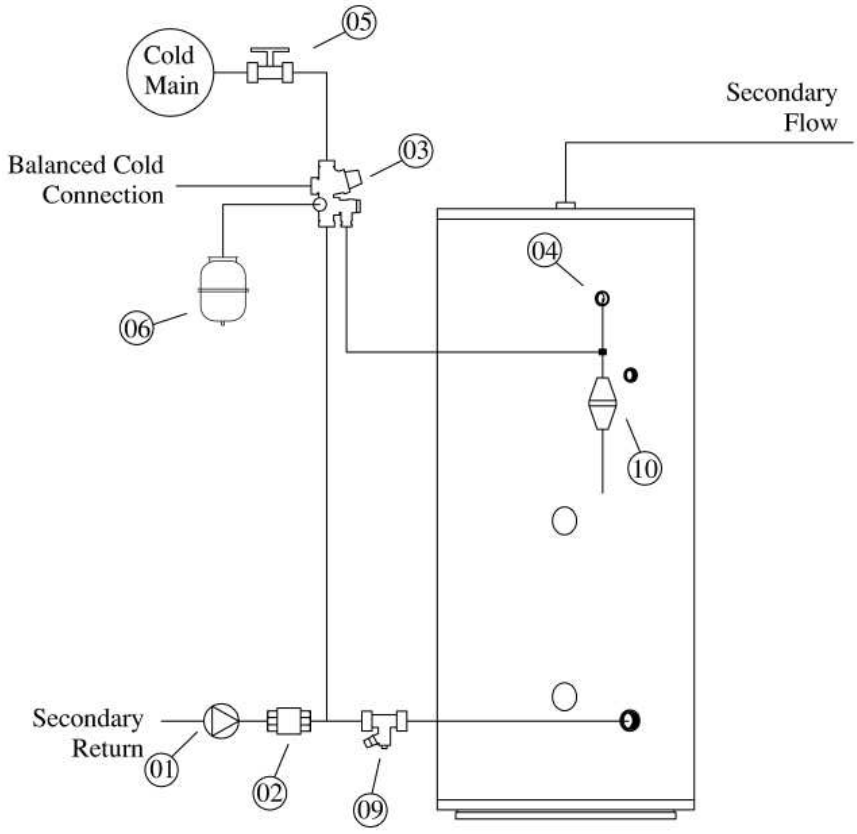

### LEGEND

01	Bronze Pump
02	Non Return Valve (Not Supplied)
03	Inlet Control Group
04	Temperature & Pressure Relief Valve
05	Isolation Valve (Not Supplied)
06	Expansion Vessel With Wall Bracket
07	Two Port Zone Valve
08	Three Port Zone Valve (Not Supplied)
09	Drain Valve (Not Supplied)
10	Tundish
11	Heating Circulation Pump (Required where boiler has no internal pump)

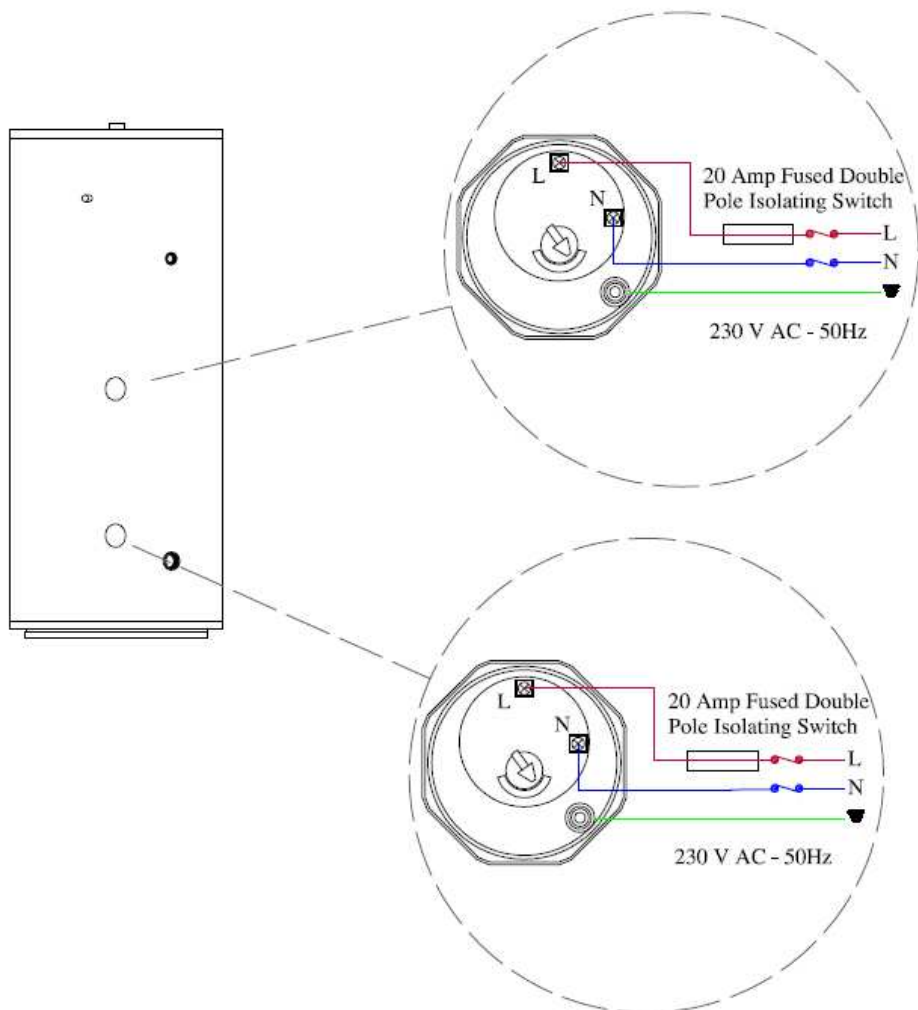

## FITTING THE IMMERSION HEATER

Always check the immersion for signs of leakage before wiring commences. The immersion heater must be completely submerged in water with a minimum of 200mm of water above the top of the immersion.

**WARNING: DONOT OPERATE THE IMMERSION HEATERS UNTIL THE CYLINDER HAS BEEN FILLED WITH WATER**

Wire the immersion through a double pole fused spur. The contact separation must be no less than 3mm with a minimum breaking capacity of 16A.

Install the immersion using rigid cable, 2m long max, with 2.5 mm<sup>2</sup> cross-section and a temperature resistance of at least 85°C.

The Cables should be rubber insulated HOFRS sheathed, complying with BS6141 Table 8. It must be fully earthed.

Ensure all terminal connections are securely made. Do not however use excessive force when tightening the terminal screws.

Ensure that the power supply is disconnected prior to making any electrical connections.

Provide 90mm length of cable for each of the Live and Neutral cables with 8mm of bare cable for connection to the Immersion terminals.

Provide 110mm length of cable for the Earth cable with 20mm of bare cable for connection to the Earth stud.

Make a circle with the bare Earth cable and tighten securely using the washer to the Earth stud.

Fit the Live and Neutral cables to the Immersion thermostat.

Ensure all terminal connections are properly tightened prior to commissioning

For installations with high water demands, or areas with hard water, Titanium immersions should be fitted.

The thermostat should be set so that the water is heated to a temperature between 60°C and 65°C. Water stored at temperatures below 60°C can result in bacteria growth and temperatures above 65°C can cause scalding.

The immersion stat has an integrated high limit stat which if the primary thermostat fails the limit thermostat takes over and shuts the element off before the water can boil in the cylinder.

### TESTING

If there is no hot water you can carry out several tests with your multimeter to decide which component is faulty.

First remove the cover for the wiring and then check for voltage across the live and neutral terminals on the element. If you get a reading the element is faulty (power going through thermostat so stat is working).

Next, check whether the thermostat is working by connecting your multimeter to the live out of the thermostat, if there is no reading the thermostat is faulty.

**NOTE: IF THE WATER IS GETTING EXTREMELY HOT THEN THE THERMOSTAT IS STUCK IN THE "ON" POSITION AND WILL NEED TO BE REPLACED.**

---

## SAFETY

Disconnect the immersion from the mains electrical supply before removing any covers.

Do not attempt to replace the immersion heater(s) with alternatives to those recommended by JOULE.

Do not bypass the Thermal Cut-Out(s) in any circumstances.

## REPLACING THE IMMERSION

First task is to isolate the power. Immersion heaters are rated at 3Kw and require their own 20amp double pole isolation switch. Turn off the power from the isolation switch and remove the fuse. Next turn off the water to the tank.

Drain the water from the tank via the drain cock using a hose. Remove the immersion using an immersion spanner. Thread in the replacement immersion heater creating the seal using a rubber o-ring or fibre washer. Slot the immersion heater into the hole with the washer and make sure the threads are lined up correctly. Tighten with whichever spanner you are using, taking care not to over tighten and risk damaging the cylinder.

Open the taps up and turn the cold water supply back on. When water starts to come out of the taps shut them off and check for leaks. If all is good wire up the immersion heater, checking that your connections are good. Fit the cap on the immersion and turn the power back on.

If the immersion is connected to a booster switch turn it on and check that it heats up. Economy 7 immersion heaters will only turn on at set times during the night and cannot be altered so check the following morning to see if the water has heated up properly.

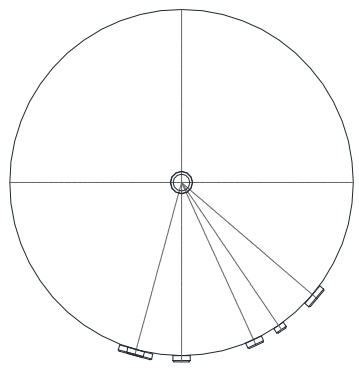
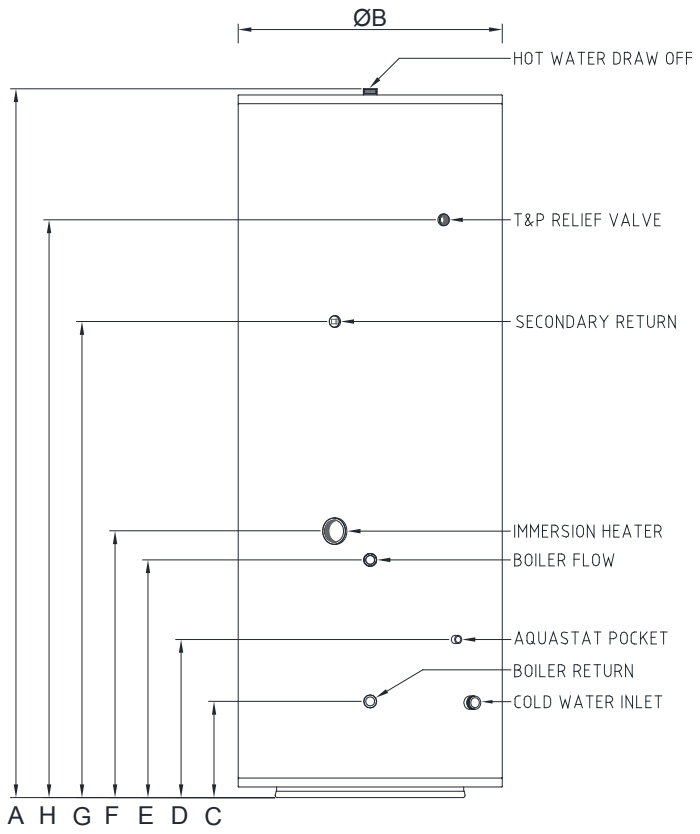

# Indirect Technical Specification

Capacity	100L	125L	150L	170L	200L	200L	250L	250L	300L	300L	400L	500L
A (mm)	950	1030	1190	1310	1150	1490	1400	1815	1600	2040	1570	1900
B (mm)	500	530	530	530	600	530	600	530	600	530	710	710
C (mm)	188	196	196	196	218	196	218	196	218	196	225	225
D (mm)	203	211	211	211	233	211	233	211	233	211	240	240
E (mm)	468	511	561	631	553	701	653	861	733	1001	740	840
F (mm)	628	651	786	881	768	981	968	1271	1153	1551	1180	1440
G (mm)	743	751	911	1031	883	1211	1133	1531	1333	1811	1280	1640
Heat Up Time (Mins)	14	23	26	27	31	31	37	37	42	42	52	54
Re-heat Time - 70% DRAW OFF (mins)	8	14	17	18	21	21	25	25	29	29	37	38
Weight - Empty (kg)	36	30	34	37	40	41	49	49	56	55	62	89
Weight - Full (kg)	135	155	184	207	240	241	299	299	356	355	462	587
Coil Surface Area (m <sup>2</sup> )	0.58			0.67			0.77			1.16	1.25	
Coil Pressure Drop (mbar)	42			65			76			88	90	
Cold Water Inlet	22mm									1" F (DN25)		
Hot Water Draw Off	22mm									1" F (DN25)		
Immersion Heater	1¾" F											
Secondary Return	½" F (BLANK)											
T&P Relief Valve	½" F (DN15)									¾" F (DN20)		
Primary Return	22mm									¾" F (DN20)		
Primary Flow	22mm									¾" F (DN20)		
Primary Heating Power (kW)	20	20	20	20	21	21	23	23	23	23	25	26
Primary Flow Rate Required To Achieve Primary Heating Power	15L/min (Primary flow rate at 80°C +/- 2°C)											
Operating Pressure	3 bar											
Maximum Design Pressure	7 bar											
Max Water Supply Pressure	10 bar											
Max Primary Working Pressure	3 bar											
Immersion Heater	3kW/240V - 1.75" - 14" Long											
Expansion Vessel Charge Pressure	2.7 bar											
Maximum Operating Temperature	90°C											
Pressure Reducing Valve Set To	3 bar											
Expansion Reducing Valve Set To	6 bar											
Pre-charge Pressure Of The Expansion Valve	3 bar											
Pressure/Temperature Relief Valve Set To	7 bar / 90°C											

Note: Heat and reheat times are a guide and are based on a primary flow temperature of 60°C and a temperature rise from 15°C to 60°C.

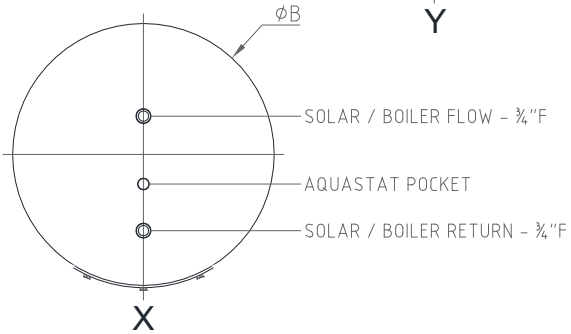
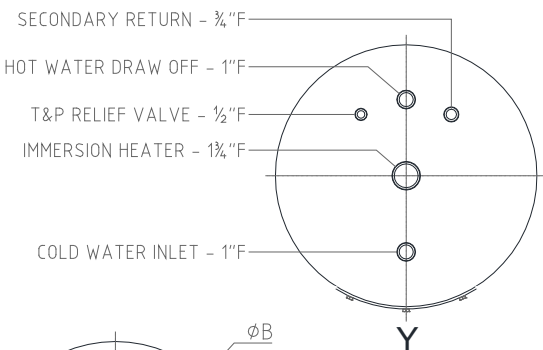
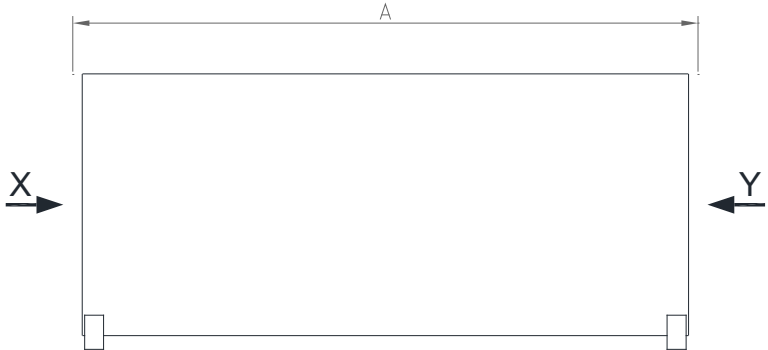

Capacity	150L	170L	200L	250L	300L
A (mm)	1140	1205	1085	1335	1535
B (mm)	530	530	600	600	600
Heat Up Time (Mins)	26	27	31	37	42
Weight - Empty (kg)	39	43	46	56	64
Weight - Full (kg)	187	210	243	302	360
Operating Pressure	3 Bar				
Max Water Supply Pressure	10 Bar				
Max Primary Working Pressure	3 Bar				

		100L	125L	150L	170L	200L	200L	250L	250L	300L	300L	400L	500L
Indirect	Hot Water Storage Tank Volume	96	124	147	168	194	196	247	247	290	289	390	495
	Standing Loss	44	52	55	58	78	81	87	89	92	103	102	115
	Energy Efficiency Class	B	B	B	B	C	C	C	C	C	D	C	C
	Standing Loss (W)	44	52	55	58	78	81	87	89	92	103	102	115
	Standing Heat Loss (kWh/24hr)	1.06	1.25	1.32	1.39	1.87	1.94	2.09	2.14	2.21	2.47	2.45	2.76

		150L (1140x530)	170L (1205x530)	200L (1085x600)	250L (1135x600)	300L (1535x600)
Indirect Horizontal	Hot Water Storage Tank Volume	148	168	194	247	290
	Standing Loss	63	69	89	97	104
	Energy Efficiency ClassC	C	C	D	D	D

According to EN 12897:2006

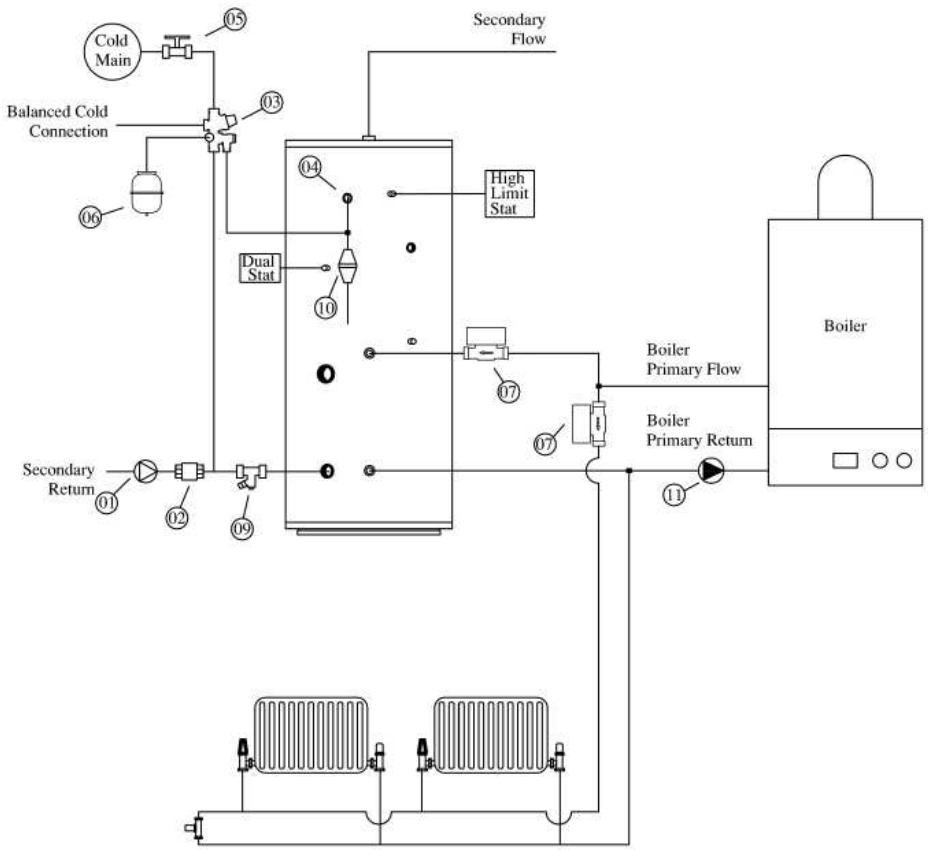

## LEGEND

01	Bronze Pump
02	Non Return Valve (Not Supplied)
03	Inlet Control Group
04	Temperature & Pressure Relief Valve
05	Isolation Valve (Not Supplied)
06	Expansion Vessel With Wall Bracket
07	Two Port Zone Valve
08	Three Port Zone Valve (Not Supplied)
09	Drain Valve (Not Supplied)
10	Tundish
11	Heating Circulation Pump (Required where boiler has no internal pump)

# Electrical Diagram

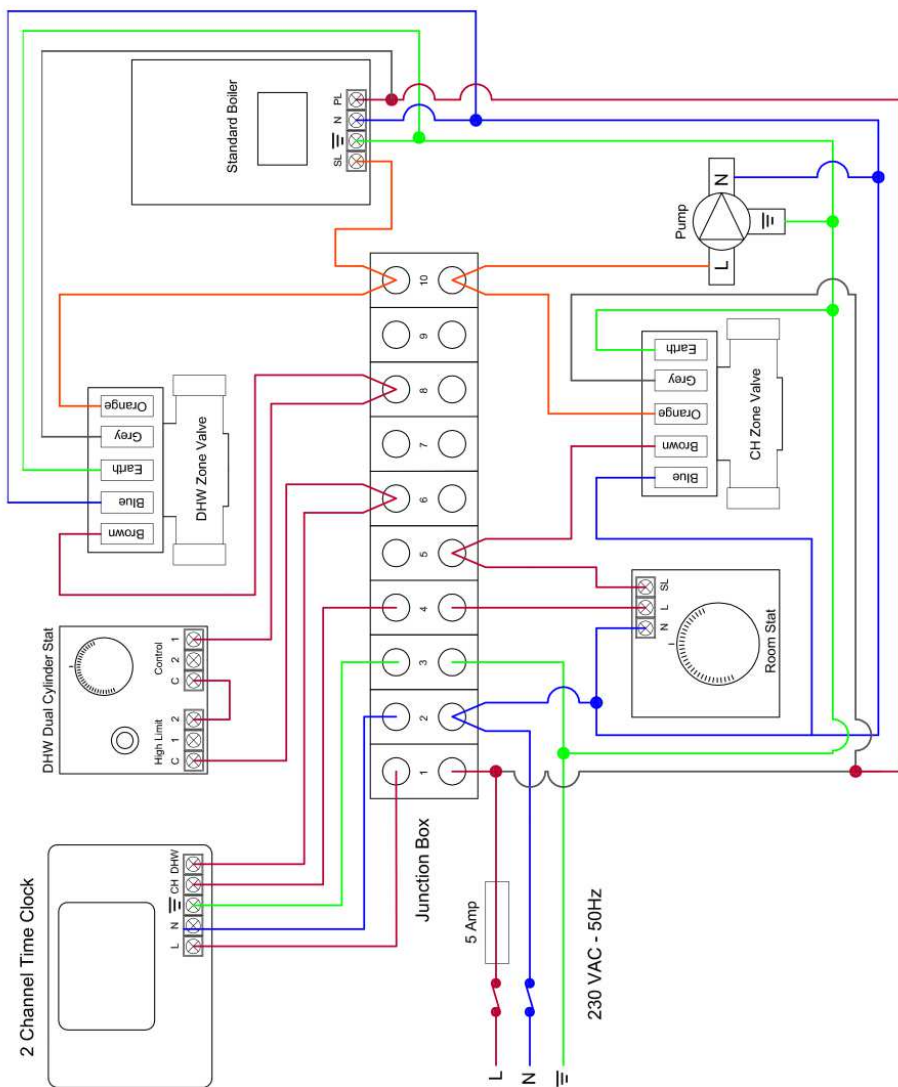

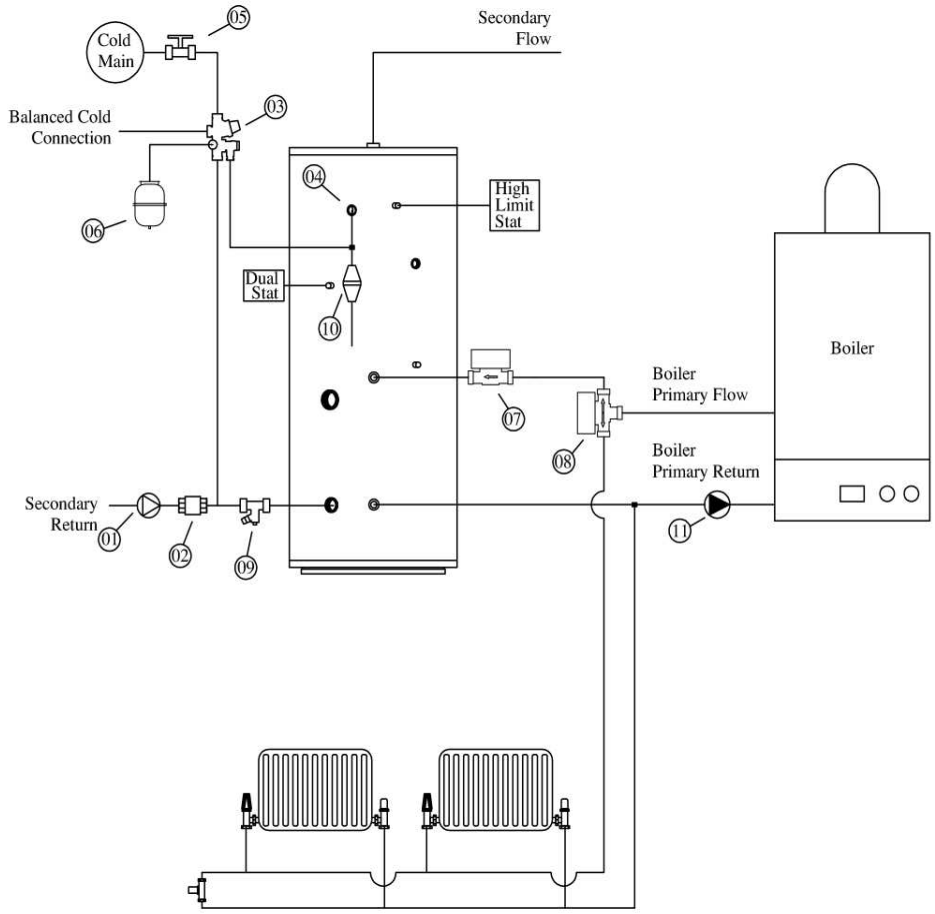

## LEGEND

01	Bronze Pump
02	Non Return Valve (Not Supplied)
03	Inlet Control Group
04	Temperature & Pressure Relief Valve
05	Isolation Valve (Not Supplied)
06	Expansion Vessel With Wall Bracket
07	Two Port Zone Valve
08	Three Port Zone Valve (Not Supplied)
09	Drain Valve (Not Supplied)
10	Tundish
11	Heating Circulation Pump (Required where boiler has no internal pump)

# Electrical Diagram

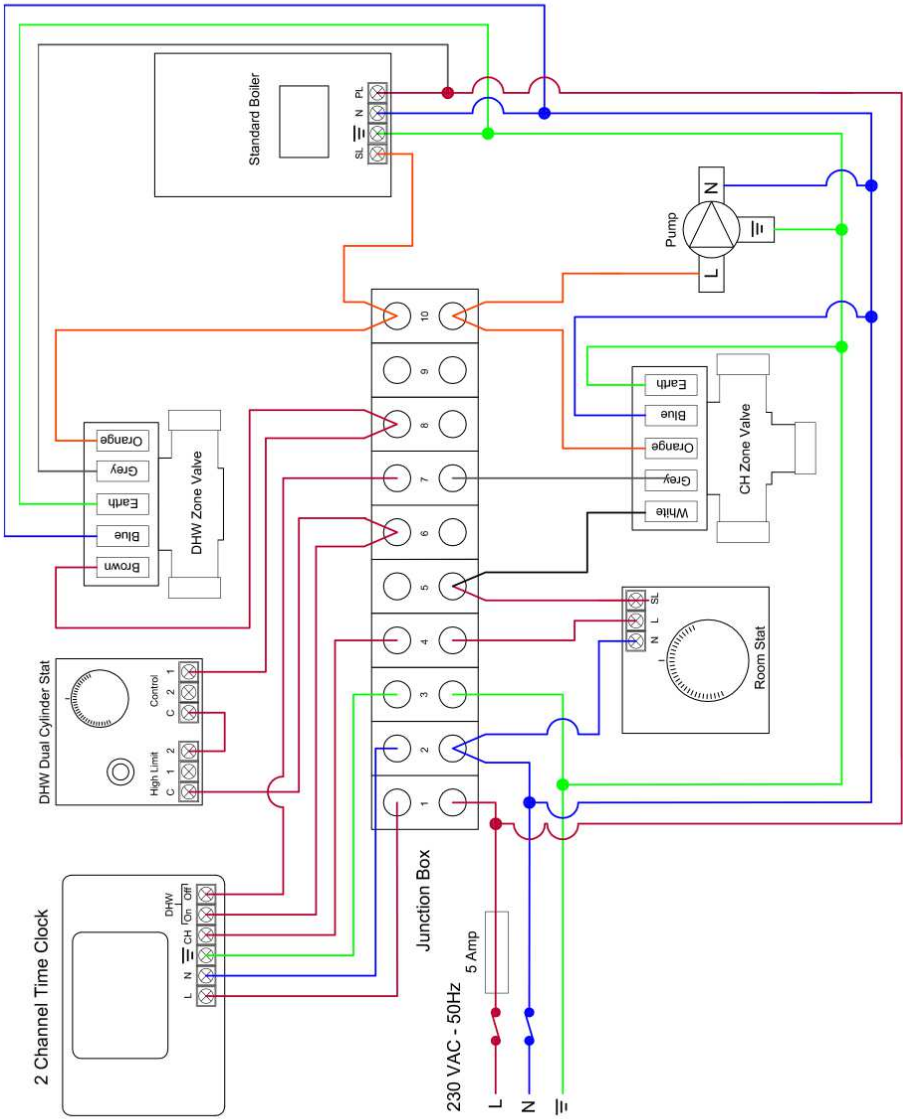

## ELECTRICAL CONTROLS

Suitable time and temperature controls should be installed to allow the cylinder to operate at its maximum efficiency. All electrical work carried out must comply with IEE Wiring Regulations (BS 3456). Products must also be installed as per the regulations in G3 of the Building Regulations. A boiler interlock should be in place and is a wiring arrangement where the boiler cannot fire unless there is a demand for hot water generation.

## TYPICAL WIRING DIAGRAMS

These diagrams relate only to the components listed. Others may vary in their wiring requirements, particularly thermostats. Always refer to manufacturers' instructions which may override the detail in order to function correctly.

## EXAMPLE

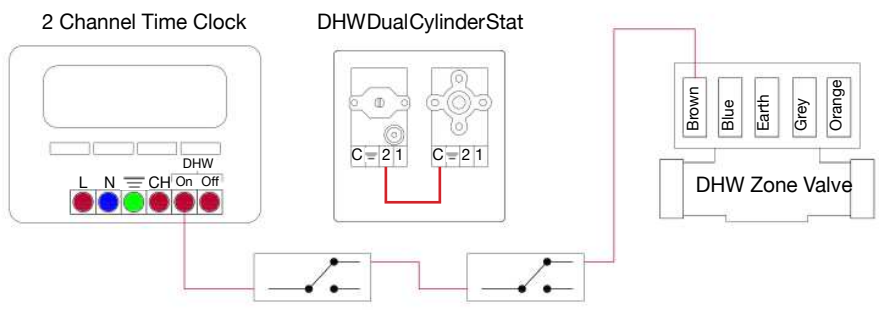

The link must be installed between the adjustable thermostat and the safety cut-out thermostat as shown above. The working thermostat which controls the temperature of the domestic hot water is adjustable. A safety cut out is also incorporated within the thermostat and will operate at  $85^{\circ}\text{C} \pm 3^{\circ}\text{C}$ . Both thermostats should run in series. To reset the safety cut-out and the motorised valve the reset button must be pressed in.

JOULE cannot be responsible if alternative wiring plans are used.

**Important:** Before resetting the safety cut-out or altering the thermostat setting isolate electrical supply to the unit before removal of the cover.

## DISCHARGE PIPEWORK

The inlet control group should be positioned so that the discharge from both safety valves can be combined via a 15mm end feed Tee, as in the diagram below. Connect the tundish and route the discharge pipe which must be routed in accordance with Building regulation - Part G3 of schedule 1.

When operating normally water will not be discharged. Water discharge from the two safety valves will only occur under fault conditions. The tundish should be vertical, located in the same space as the unvented hot water storage system and be fitted as close as possible, and lower than the valve, with no more than 600mm between the safety device outlet e.g. the temperature relief valve and the tundish.

The position of the tundish must be that when installed it is visible to the occupants of the premises. When positioning the tundish, the drain valves and motorised valve ensure that these items are positioned away from any electrical devices. The discharge pipe (D2) coming from the tundish should terminate in a safe place where there is no risk to persons in the vicinity of the discharge, be of metal and:

Be at least one pipe size larger than the nominal outlet size of the safety device unless its total equivalent hydraulic resistance exceeds that of a straight pipe 9m long, i.e. discharge pipes between 9m and 18m equivalent resistance length should be at least two sizes larger than the nominal outlet size of the safety device, between 18 and 27m at least 3 sizes larger, and so on.

Bends must be taken into account in calculating the flow resistance. Refer to diagram 1, Table 1 and the worked example. An alternative approach for sizing discharge pipes would be to follow BS6700 Specification for design, installation, testing and maintenance of services supplying water for domestic use within buildings and their curtilages.

Have a vertical section of pipe at least 300mm long, below the tundish before any elbows or bends in the pipework.

Be installed with a continuous fall.

It is preferable for the discharge to be visible at both the tundish and the final point of discharge. Where this is not possible or practically difficult, there should be clear visibility at one or other of these locations

## EXAMPLES OF ACCEPTABLE DISCHARGEMENT ARRANGEMENTS

Ideally below the fixed grating and above the water seal in a trapped gully.

Downward discharges at a low level; i.e. up to 100mm above external surfaces such as car parks, hard standings, grassed areas etc. are acceptable providing that where children play or otherwise come into contact with discharges, a wire cage or similar guard is positioned to prevent contact whilst maintaining visibility.

Discharges at a high level; e.g. in to metal hopper and metal down pipe with the end of the discharge pipe clearly visible (tundish visible or not) or onto a roof capable of withstanding high temperature discharges of water and 3m from any plastic guttering systems that would collect such discharges (tundish available).

Where a single pipe serves a number of discharges, such as in blocks of flats, the number served should be limited to not more than 6 systems so that any installation can be traced reasonably easily.

The single common discharge pipe should be at least one pipe size larger than the largest individual discharge pipe to be connected. If unvented hot water storage systems are installed where discharges from safety devices may not be apparent, i.e. in dwellings occupied by blind, infirm or disabled people, consideration should be given to the installation of an electronically operated device to warn when discharge takes place.

## WORKED EXAMPLE

The example on the next page is for G1/2 temperature relief valve with a discharge pipe (D2) having 4 No. elbows and length of 7m from the tundish to the point of discharge.

Maximum resistance allowed for a straight length of 22mm copper discharge pipe (D2) from a G1/2 temperature relief valve is: 9.0m. Subtract the resistance for 4 No. 22mm elbows at 0.8m each = 3.2m. Therefore the maximum permitted length equates to: 5.8m. 5.8m is less than the actual length of 7m, therefore calculate the next largest size.

Maximum resistance allowed for a straight length of 28mm pipe (D2) from a G1/2 temperature relief valve equates to: 14m. As the actual length is 7m, a 28mm (D2) copper pipe will be satisfactory.

Size of discharge pipework	Maximum length of straight pipe (no bends or elbows)	Deduct the figure below from the maximum length for each bend or elbow in the discharge pipe
22mm	Up to 9m	0.8m
28mm	Up to 18m	1m
35mm	Up to 27m	1.4m

Table 4.a - Sizing of copper discharge pipe (D2) for a temperature relief balbe with a G1/2 outlet size (as supplied)

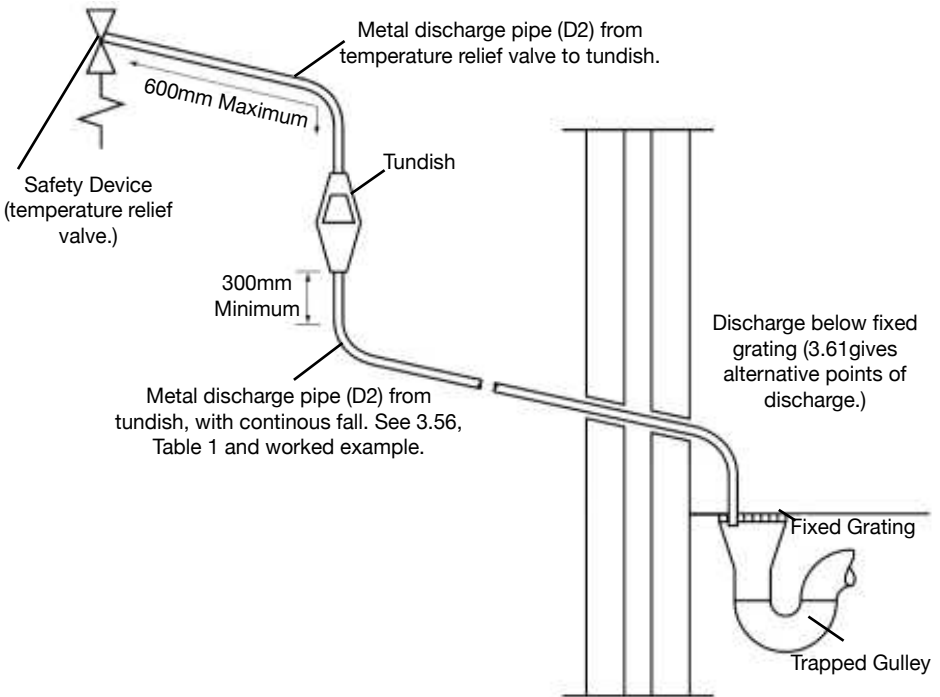

Figure 4.b

Note: It is not acceptable to discharge straight into a soil pipe.

Note: The discharge will consist of scalding water and steam. Asphalt, roofing felt and non-metallic rainwater goods may be damaged by such discharges.

## FILLING

First you must ensure that the pressure in the expansion vessel is the same as the setting of the pressure reducing valve i.e. 3bar (45PSI). The valve is of the Schrader car tyre type. Check all the connections for water tightness including any factory made connections such as the immersion heater and the temperature and pressure relief valve. Prior to filling, open the hot tap furthest away from the cylinder to expel air. Open the cold main isolation valve and allow the unit to fill.

Once the cylinder has been fully commissioned it should be heated to its normal operating temperature. Draw off secondary hot water to each outlet and allow hot water to flow from each outlet for at least 30 seconds to remove any flux residue from the pipe work within the secondary hot water system. Then fully drain the cylinder and re-fill to ensure that all flux residues is removed from the system.

## INDIRECT UNITS

Fill the primary circuit according to the boiler manufacturers' commissioning instructions. Any additives used in the heating system water circulating through the cylinder coil must be compatible for use with stainless steel cylinders.

Ensure the lever on the two port valve is set to the filling position. When full, move the lever back. Switch the programmer to Domestic Hot Water (DHW) and allow the unit to start to heat. Adjust the dial of the dual thermostat to between 30°C and 70°C as required.

## STORAGE TEMPERATURE

60-65°C is the recommended storage temperature for both direct and indirect cylinders. In hard water areas consideration should be given to reducing this to 50-55°C. In many healthcare applications the guidance on Legionella control and safe water delivery temperatures will require storing the water at 60-65°C, distributing at 50-55°C and using thermostatic mixing valves to control the final temperature. For details consult the NHS Estates Guidance on safe hot water temperatures.

## GENERAL

Service should only be carried out by competent installers and any spare parts used must be purchased from JOULE.

**NEVER** bypass any safety devices or operate the unit without them being fully operational.

## DRAINING

Switch the electrical power off (important to avoid damage to element). Isolate boiler from the unit. Turn off the cold water supply valve. Open hot water tap. Open the drain valve. The unit will drain.

**WARNING: WATER DRAINED OFF MAY BE VERY HOT!**

## ANNUAL MAINTENANCE

The water heaters require annual servicing in order to ensure safe working and optimum performance. It is essential that the following checks are performed by a competent installer on an annual basis. This is commonly done at the same time as the annual boiler service.

Twist the cap of the expansion relief valve on the inlet control set and allow water to flow for 5 seconds. Release and make sure it resets correctly.

Repeat with the pressure / temperature relief valve. In both cases check that the discharge pipework is carrying the water away adequately. If not, check for blockages etc. and clear.

Check that any immersion heaters fitted are working correctly and that they are controlling the water at a temperature between 55°C and 65°C.

Check the pressure in the expansion vessel is charged to 3 bar. Turn off the water supply to the unit and open a hot tap first. The air valve on expansion vessel is a Schrader (car tyre) type.

Air or CO<sub>2</sub> may be used to charge the expansion vessel. Unscrew the head on the inlet control set and clean the mesh filter within.

The Service Log Book supplied with this unit should be updated at each service.

**YOUR GUARANTEE MAY BE VOID IF YOU CANNOT PRODUCE PROOF OF ANNUAL SERVICING**

## IMMERSION HEATER REPLACEMENT

If the thermal cut out on the Immersion heater operates contact a competent installer. If the thermal cut out fault occurs again the immersion will need to be replaced.

Prior to installing the replacement Immersion, ensure the o-ring is correctly positioned on the head of the Immersion and lubricate the threads before fitting.

Thread the Immersion by hand until it is hand tight and then tighten gently to allow the o-rings to create a water tight seal.

## INSPECTION

Where internal inspection of the cylinder is required an endoscope can be used. Inspection can be carried out by draining down the cylinder and removing a component that is fitted to a wet connection in the cylinder.

## SAFETY VALVE CHECKS

From either the temperature/pressure relief valve or the expansion relief valve indicates a problem.

Check your discharge pipework is free from debris and is carrying water away to waste effectively. Next hold both of these safety valves open, allowing as much water as possible to flow through the tundish. Release the valves and check that they reseat correctly.

Completion of the Benchmark checklist on pages 40-41 **MUST** be adhered to by the installer.

## SHUTTING DOWN

Ensure the cold water supply is isolated and at least two hot water draw off points are open prior to draining the cylinder.

One of the hot water draw off points should be as close as possible to the height of cylinder in draw off terms.

Where applicable use the drain valve at the cold water inlet to drain the contents of the cylinder.

Isolate the coil from the main heating system. If necessary blow out the coil prior to moving the cylinder.

## RECYCLING AND DISPOSAL

The cylinder or any of its components must not be disposed of in domestic rubbish. The material in the cylinder, packaging and components contain recyclable materials and they should be disposed of properly and in accordance with national regulations.

## GUIDANCE IN THE EVENT OF A PROBLEM

If you have a problem in the first year, contact the plumber who fitted the unit. Thereafter contact the plumber who carries out the annual servicing for you. If your cylinder develops a leak we will supply you with a new one. We ask for a nominal upfront payment to prevent fraud and we will require the original unit to be returned to us for inspection along with a copy of your Service Log Book. If it is confirmed that it has failed within the terms of the guarantee your upfront payment will be refunded.

If a component part fails within the guarantee period, we will send you a new one without any upfront charge. Credit card details may be taken to prevent fraud. We ask you to post the faulty part back to us within one month by recorded delivery.

If you do not return the part we will charge you for it and for the postage and packing. If your part fails after the guarantee period, we will ask for upfront payment.

## LOG BOOK

The installer must comply with all of the installation instructions contained within this installation manual. On completion of the initial installation and after each subsequent annual service the Benchmark Log Book must be completed and signed by the competent person who has worked the unit.

The purpose of Benchmark is to ensure that customers have the correct equipment for their requirements installed in accordance with the manufacturer's installation instructions. The equipment must be installed by installers who have completed an accredited competent person's scheme and who install, commission and service the equipment in accordance with the manufacturer's instructions.

All installations must comply with the appropriate Building Regulations and the Benchmark Log Book should be provided to the customer. The Benchmark Log Book can also be used to show that all equipment is installed in accordance with the relevant Building Regulations.

Your stainless system is automatic in normal use and requires only annual servicing. You should employ a competent installer to perform the annual servicing. Normally this is timed to coincide with the annual boiler service.

**IF WATER IS FLOWING FROM THE SAFETY VALVE THROUGH THE TUN DISH THIS INDICATES A FAULT CONDITION AND ACTION IS NEEDED.**

If this water is hot, turn the boiler and / or the immersion heater off. Do not turn off the water until the discharge runs cool. The discharge may also stop.

**CALL OUT A COMPETENT PLUMBER TO SERVICE THE UNIT.**

Tell them you have a fault on an unvented cylinder. We stock all the spare parts they may need and JOULE can be contacted via telephone numbers on back page.

Fault	Possible Cause	Solution
Water escaping from the case unit.	Compression fitting on hot - draw off not sealing.	Check / remake joint sealing paste.
Cold water at hot tops.	Immersion heater not switched on or cutout has triggered.	Check / reset.
	Indirect - Boiler not working.	Check boiler - consult boiler manufactures' instructions.
	Indirect - motorized valve fault.	Check plumbing / wiring motorized valve.
	Indirect - cutout in dual stat has operated.	Check outlet pressure from inlet control set is 3 bar.
Water discharges from expansion relief valve	If continual - pressure reducing valve (part of inlet control set ) mayno tbe operating correctly.	Check outlet pressure from inlet control set is 3 bar.
	If continual - expansion relief valve seat may be damaged.	Remove cartridge - check seat and renew if necessary.
	If intermittent - expansion vessel charge may have reduced / bladder perished.	Check pressure in expansion vessel. Recharge to 3 bar if necessary. If bladder perished replace vessel.
	Unit is being back pressurized.	With cylinder cold check pressure in cylinder. If this is the same as the incoming mains pressure then you are getting backfeed. Install a balanced cold supply.
Water discharges from temperature & pressure relief valve	Unit has overheated - thermal controls have failed.	Switched off power to boiler and immersion heaters. Leave water supply on. Wait until discharges stops. Isolate water supply and replace if faulty.
Milky / cloudy water	Oxygenated Water.	Water from any pressurized system will release oxygen bubbles when flowing. The bubbles will settle out.
No hot water flow	Cold main off.	Check and open stopcock.
	Strainer blocked in pressure reducing valve.	Isolate water supply and clean.
	Inlet control set may be fitted incorrectly.	Check and refit required.
Noise during hot water draw off - typically worse in the morning	Loose airing cupboard pipework.	Install extra clips.
Hot or warm water from cold tap	If tap runs cold after a minute or so the pipe is picking up heat from heating pipework.	Insulate/re-route.

## CYCLONE GUARANTEE – CC/001 – 13/10/15

### Joule Cyclone

The JOULE Cyclone stainless steel vessel carries a fully transferable 25-year guarantee against faulty materials or manufacture provided that:

- It has been installed in the United Kingdom or the Republic of Ireland as per the instructions provided in the installation manual provided with the cylinder and in accordance with all of the relevant standards, regulations and codes of practice in force at the time.
- It has not been modified in any way, other than by JOULE
- It has not been misused, tampered with or subjected to neglect.
- The system is fed from the public mains water supply.
- It has only been used for the storage of potable water.
- It has not been subjected to frost damage.
- The unit has been serviced annually.
- The Service Log Book has been completed after each annual service.

### Exclusions

The guarantee does not cover cylinders affected by the following;

- The effects of scale build up on the cylinder.
- Any labour charges associated with replacing the unit or its parts.
- Any consequential losses caused by the failure or malfunction of the unit.
- Please note that invoices for servicing may be requested to prove that the unit has been serviced annually.

### Unvented Kit

The expansion vessel and cold water controls supplied with JOULE models carry a 2-year guarantee. All other components that are fitted to, or supplied, with the unit carry a 2-year guarantee.

### Joule Wellmaster

The JOULE Wellmaster stainless steel vessel carries a fully transferable 20-year guarantee against faulty materials or manufacture provided that:

- It has been installed in the United Kingdom or the Republic of Ireland as per the instructions provided in the installation manual provided with the cylinder and in accordance with all of the relevant standards, regulations and codes of practice in force at the time.
- It has not been modified in any way, other than by JOULE.
- It has not been misused, tampered with or subjected to neglect.
- It has only been used for the storage of potable water.









This Commissioning Checklist is to be completed in full by the competent person who commissioned the storage system as a means of demonstrating compliance with the appropriate Building Regulations and then handed to the customer to keep for future reference. Failure to install and commission this equipment to the manufacturer's instructions may invalidate the warranty but does not affect statutory rights.

Customer Name \_\_\_\_\_ Telephone Number \_\_\_\_\_  
 Address \_\_\_\_\_  
 Cylinder Make and Model \_\_\_\_\_  
 Cylinder Serial Number \_\_\_\_\_  
 Commissioned by (print name) \_\_\_\_\_ Registered Operative ID Number \_\_\_\_\_  
 Company Name \_\_\_\_\_ Telephone Number \_\_\_\_\_  
 Company Address \_\_\_\_\_ Commissioning Date \_\_\_\_\_

**To be completed by the customer on receipt of a Building Regulations Compliance Certificate\*:**  
 Building Regulations Notification Number (if applicable) \_\_\_\_\_

**ALL SYSTEMS PRIMARY SETTINGS (indirect heating only)**

Is the primary circuit a sealed or open vented system? Sealed  Open   
 What is the maximum primary flow temperature? \_\_\_\_\_ °C

**ALL SYSTEMS**

What is the incoming static cold water pressure at the inlet to the system? \_\_\_\_\_ bar

Has a strainer been cleaned of installation debris (if fitted)? Yes  No

Is the installation in a hard water area (above 200ppm)? Yes  No

If yes, has a water scale reducer been fitted? Yes  No

What type of scale reducer has been fitted? \_\_\_\_\_ °C

What is the hot water thermostat set temperature? \_\_\_\_\_ /min

What is the maximum hot water flow rate at set thermostat temperature (measured at high flow outlet)? \_\_\_\_\_ /min

Time and temperature controls have been fitted in compliance with Part L of the Building Regulations? Yes

Type of control system (if applicable) Y Plan  S Plan  Other

Is the cylinder solar (or other renewable) compatible? Yes  No

What is the hot water temperature at the nearest outlet? \_\_\_\_\_ °C

All appropriate pipes have been insulated up to 1 metre or the point where they become concealed? Yes

## UNVENTED SYSTEMS ONLY

Where is the pressure reducing valve situated (if fitted)?

What is the pressure reducing valve setting?  bar

Has a combined temperature and pressure relief valve and expansion valve been fitted and discharge tested? Yes  No

The tundish and discharge pipework have been connected and terminated to Part G of the Building Regulations Yes

Are all energy sources fitted with a cut out device? Yes  No

Has the expansion vessel or internal air space been checked? Yes  No

## THERMAL STORES ONLY

What store temperature is achievable?

What is the maximum hot water temperature?  °C

## ALL INSTALLATIONS

The hot water system complies with the appropriate Building Regulations  Yes

The system has been installed and commissioned in accordance with the manufacturer's instructions Yes

The system controls have been demonstrated to and understood by the customer Yes

The manufacturer's literature, including Benchmark Checklist and Service Record, has been explained and left with the customer Yes

Commissioning Engineer's Signature \_\_\_\_\_

Customer's Signature \_\_\_\_\_

*(To confirm satisfactory demonstration and receipt of manufacturer's literature)*

\*All installations in England and Wales must be notified to Local Authority Building Control (LABC) either directly or through a Competent Persons Scheme. A Building Regulations Compliance Certificate will then be issued to the customer.



www.centralheating.co.uk

Viessmann - 5366822

## SERVICE RECORD

It is recommended that your hot water system is serviced regularly and that the appropriate Service Record is completed.

### Service Provider

Before completing the appropriate Service Record below, please ensure you have carried out the service as described in the manufacturer's instructions.

#### SERVICE 1 Date \_\_\_\_\_

Engineer Name \_\_\_\_\_

Company Name \_\_\_\_\_

Telephone Number \_\_\_\_\_

Comments \_\_\_\_\_  
\_\_\_\_\_  
\_\_\_\_\_  
\_\_\_\_\_

Signature \_\_\_\_\_

#### SERVICE 2 Date \_\_\_\_\_

Engineer Name \_\_\_\_\_

Company Name \_\_\_\_\_

Telephone Number \_\_\_\_\_

Comments \_\_\_\_\_  
\_\_\_\_\_  
\_\_\_\_\_  
\_\_\_\_\_

Signature \_\_\_\_\_

#### SERVICE 3 Date \_\_\_\_\_

Engineer Name \_\_\_\_\_

Company Name \_\_\_\_\_

Telephone Number \_\_\_\_\_

Comments \_\_\_\_\_  
\_\_\_\_\_  
\_\_\_\_\_  
\_\_\_\_\_

Signature \_\_\_\_\_

#### SERVICE 4 Date \_\_\_\_\_

Engineer Name \_\_\_\_\_

Company Name \_\_\_\_\_

Telephone Number \_\_\_\_\_

Comments \_\_\_\_\_  
\_\_\_\_\_  
\_\_\_\_\_  
\_\_\_\_\_

Signature \_\_\_\_\_

**SERVICE 5** Date \_\_\_\_\_

Engineer Name \_\_\_\_\_

Company Name \_\_\_\_\_

Telephone Number \_\_\_\_\_

Comments \_\_\_\_\_

\_\_\_\_\_

\_\_\_\_\_

\_\_\_\_\_

Signature

**SERVICE 6** Date \_\_\_\_\_

Engineer Name \_\_\_\_\_

Company Name \_\_\_\_\_

Telephone Number \_\_\_\_\_

Comments \_\_\_\_\_

\_\_\_\_\_

\_\_\_\_\_

\_\_\_\_\_

Signature

**SERVICE 7** Date \_\_\_\_\_

Engineer Name \_\_\_\_\_

Company Name \_\_\_\_\_

Telephone Number \_\_\_\_\_

Comments \_\_\_\_\_

\_\_\_\_\_

\_\_\_\_\_

\_\_\_\_\_

Signature

**SERVICE 8** Date \_\_\_\_\_

Engineer Name \_\_\_\_\_

Company Name \_\_\_\_\_

Telephone Number \_\_\_\_\_

Comments \_\_\_\_\_

\_\_\_\_\_

\_\_\_\_\_

\_\_\_\_\_

Signature

**SERVICE 9** Date \_\_\_\_\_

Engineer Name \_\_\_\_\_

Company Name \_\_\_\_\_

Telephone Number \_\_\_\_\_

Comments \_\_\_\_\_

\_\_\_\_\_

\_\_\_\_\_

\_\_\_\_\_

Signature

**SERVICE 10** Date \_\_\_\_\_

Engineer Name \_\_\_\_\_

Company Name \_\_\_\_\_

Telephone Number \_\_\_\_\_

Comments \_\_\_\_\_

\_\_\_\_\_

\_\_\_\_\_

\_\_\_\_\_

Signature

#### JOULE IE

**mail** Kylemore Park West, Ballyfermot, Dublin 10  
**tel** +353 (1) 623 7080  
**fax** +353 (1) 626 9337  
**eml** info@joule.ie  
**web** www.joule.ie

#### JOULE UK

**mail** Unit 17C&D Power Road, Plantation Bus. Pk.  
Bromborough, Wirral, CH62 3RN  
**tel** +44 (0) 1513 551 094  
**fax** +44 (0) 1513 568 336  
**eml** info@jouleuk.co.uk  
**web** www.jouleuk.co.uk

#### JOULE PL

**mail** 23-200 Kraśnik, ul. Towarowa 34.  
**tel** +48 (0) 128811171  
**fax** +48 (0) 814709046  
**eml** biuro@joule-pl.pl  
**web** www.joule-pl.pl