

RAVENHEAT®

Innovating new technology into gas boilers



CS80 (1)
CS90 (1)

YEAR **2**
GUARANTEE

10-12
LITRES
A MINUTE

WHISPER
QUIET

Low
Nox
CLASS
5

29kg
SINGLE
MAN
LIFT

HIGH PERFORMANCE COMBI

Not all boilers are the same – just take a look at what the Ravenheat CS80, CS90 and System boilers have to offer:

CS80 Combination Boiler – 25kW to domestic hot water (DWH) output with a flow rate of 10.2 litres through 35°C rise.

CS90 Combination Boiler – 30kW output to DWH with a DWH flow rate of 12 litres through a 35°C rise.

- SEDBUK A rated.
- 2 year guarantee.*
- Compact in size – 700mm high, 400mm wide and 300mm deep.
- Innovative low energy consumption.
- Exceptionally quiet in operation.
- Large digital visible temperature adjustment.
- User friendly touch controls, simple and easy to use.
- Integral valve kit eliminates unsightly valves outside the boiler.
- Built-in deep seal condensation trap designed to reduce nuisance freezing in winter.
- Flexible condensation pipe conveniently located after the trap.
- Manual and automatic air vent allows air out of the system more easily when commissioning.
- Brass and premium branded components for lasting quality.
- The high density foam lining of the CS80 and CS90 keeps heat in and allows for quiet operation.

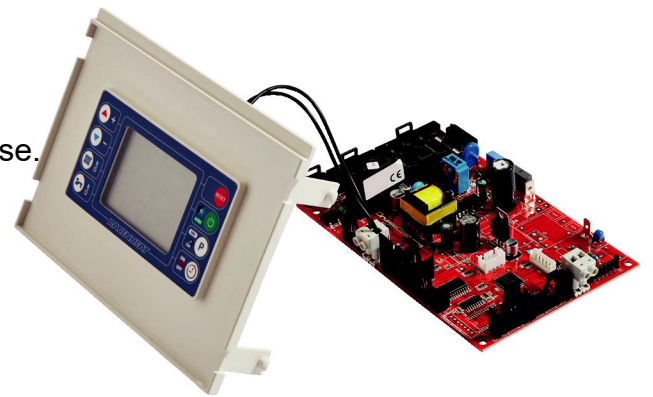

- Removable side panels.
- Built-in automatic by-pass.
- Low NOx class 5 meets new stringent building codes.
- The weather compensator option makes the boilers perfect for new-build projects.
- Solar compatible.
- Minimum low power of 3.6kW further reduces energy cost.
- Greater Energy Saving through the appliance modulating.
- Lightweight design to aid installation.

Flue options

The new CS80 & CS90 can be fitted with either a 100mm standard (concentric), a 125mm flue duct or a twin (eccentric) flue duct, which can be installed either vertical or horizontal, depending on the customer's requirement. A one metre standard horizontal flue kit is supplied separately; this can extend to 8 metres if required, or 13 metres vertical (maximum without bends). The above flue arrangements should fit most requirements however, alternative systems (Twin or 125mm) are available. See installation manual for all flue options.

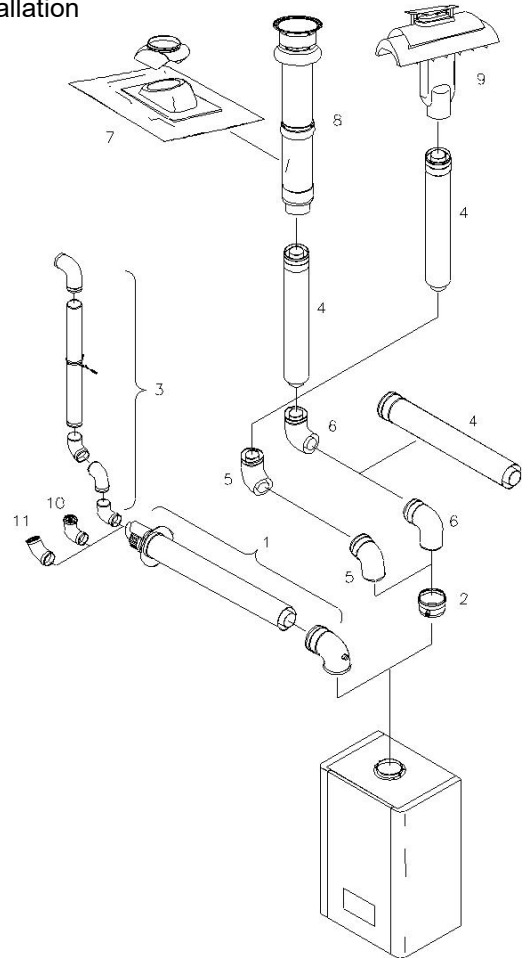

Alternative systems (twin or 125mm) are available for longer flue distance.



Part	Description Flue 60/100	Part No
1	1 metre horizontal flue kit	PR5023016
2	Straight flue header/Sample Point	PR5094110A
3	1 metre high plume kit	TER110101
4	1 metre flue extension	PRFE
5	45° in line flue bend	PR45FBI
6	90° in line flue bend	PR90FBI
7	Flashing sleeve/plate	TEG060050
8	1 metre vertical terminal	TER110200
9	Combi ridge terminal kit	TER090100
10	90° flue exhaust deflection bend	CUR110100
11	45° flue exhaust deflection bend	CUR110050

Easily installed neat connections

Quality

Built to exacting ISO 9001 standards using quality components, all our boilers carry the European CE mark. Each Ravenheat appliance undergoes rigorous testing and operating procedure before being carefully packed for maximum protection, ready to leave our factory.

We only use high quality components from leading industry manufacturers: Honeywell, Grundfos and Gianni.

Boiler Specifications

	Model	CS80(T)	CS90(T)	CS System 3-20	CS System 4-24
Central Heating Max Output (Adjustable Modulation)	kW	3.6 - 21.4	4.0 - 26.2	3.6 - 21.4	4.0 - 26.2
Domestic Hot Water Max Output (Adjustable Modulation)	kW	3.6 - 25.4	4.0 - 30.0	-	-
Domestic Hot Water Flow Rate Raised 30°C Δt	l/Min	11.9	14.0	-	-
Inlet Temperature 35°C Δt	l/Min	10.2	12.0	-	-
Expansion Vessel	1	8L	8L	8L	8L
Maximum Central Heating Temperature	°C	80	80	80	80
Installation Clearance					
Side	mm	50	50	50	50
Top	mm	125	125	125	125
Below	mm	80-150	80-150	80-150	80-150
Connection					
Heating Flow & Return Compression	mm	22	22	22	22
Gas Connection	mm	15	15	15	15
Domestic Supply (Cold) Compression	mm	15	15	-	-
Domestic Supply (Hot) Copper	mm	15	15	-	-
Condensing Pipe ¾ Push Fit Overflow Pipe					
Flue Size	mm	100	100	100	100
Electrical Mains Supply		230V 50Hz Fused 3amp	230V 50Hz Fused 3amp	230V 50Hz Fused 3amp	230V 50Hz Fused 3amp
Nat Gas A Band A 2005/2009	%	90.3/88.9	90.3/88.9	90.4/89	90.4/88.9
Nox Class (lowest possible level)		5	5	5	5
Available with or without timer		19 Mg / kWh		19 Mg / kWh	



* For any other information please refer to user guide and installation instructions.

Technical After-Sales Service

Ravenheat have a technical helpline at its central headquarters in Leeds. Service engineers or their customers have the satisfaction of knowing they will receive advice, and the knowledge that one of Ravenheat's own technicians is on hand should an on-site visit be required. Ravenheat only use their own highly qualified technicians thereby ensuring the highest quality and most reliable customer care.

Ravenheat run their own unique comprehensive installer training programme working alongside the regulative bodies and trade associations. The training programme is open to any Gas Safe Registered installer. For further information about our training days simply contact us via our internet website www.ravenheat.co.uk or by requesting further information via e-mail: enquiries@ravenheat.co.uk.



CONDITIONS OF 2 YEAR WARRANTY – Boiler must be correctly installed. Boiler must be commissioned by a Gas Safe registered engineer. Boiler must be registered with Ravenheat upon purchase (so 2 year warranty can be activated). Boiler must be correctly maintained and serviced by a qualified, competent person. For any other information please refer to user guide and installation instructions.



Order at online @ <https://www.mepstock.co.uk/>

mepstock
.co.uk